

40/10 PM ROUND R2

Automatic horizontal sliding car door



NEW INSTALLATION



RESIDENTIAL
LIFTS



COMMERCIAL
LIFTS

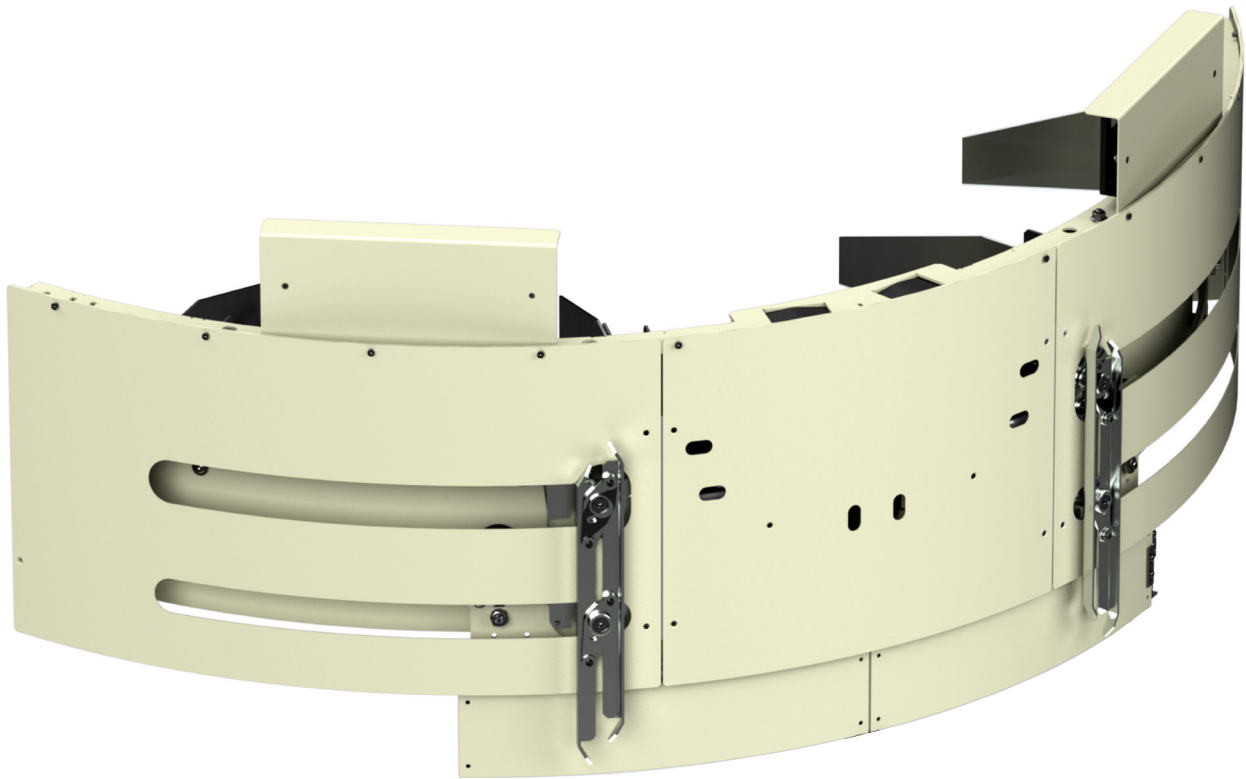

Segmentation

New Installation

Residential lifts

Commercial lifts

Lift application

Door cycles per year: Up to 800.000

Traffic peak of the door: Up to 240 cycles per hour

Traffic lift speed: Up to 2,5 m/s

Range

Opening

Min. Radius

PL

HL

C2

550 mm

600 - 1.100 mm

2.000 - 2.600 mm

Panels

Sheet metal, Full glass in skirting

Drive

Power supply

Electronic module

Safety Code

230 V AC

VF7+ Relay / VF7+ CAN

EN 81-1/2

230 V AC

VF7+ Relay / VF7+ CAN

EN 81-20/50

Main features

Simplified installation and maintenance for operator parts, CDL and electronic module

Improved smooth operation through vector control

Operator compact design

Ask the commercial department for more combinations details.

General dimensions

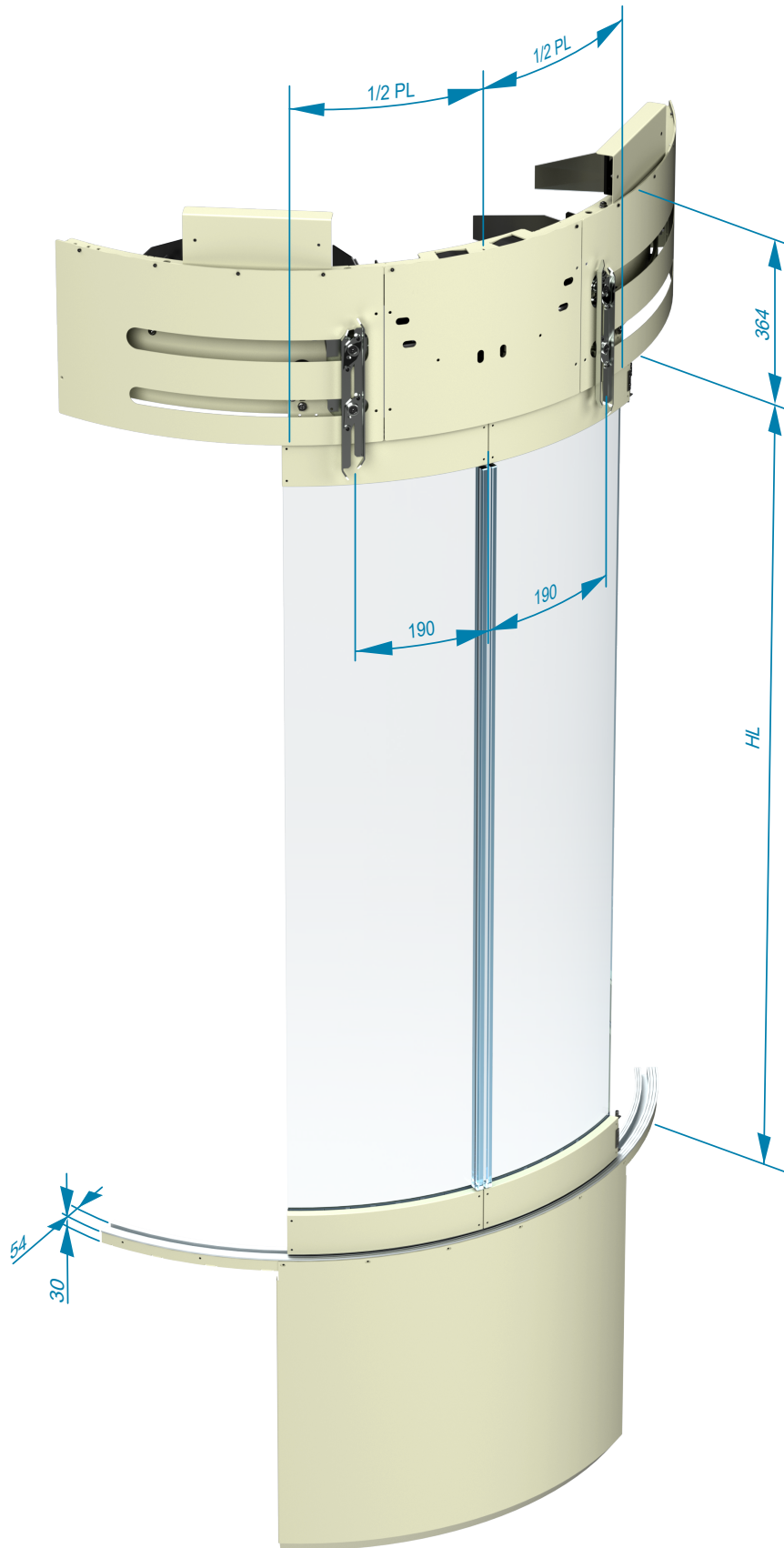



Sales contacts

General

info@fermator.com

Manufacturing companies

Brazil: info.br@fermator.com • China: info.cn@fermator.com • France: info.hp@fermator.com • India: info.in@fermator.com
Italy: info.it@fermator.com • Poland: info.pl@fermator.com • Spain: info.es@fermator.com

Trading companies

France: info.ff@fermator.com • Germany: info.de@fermator.com • Middle East: info.tr@fermator.com
Nordic countries: info.se@fermator.com • United Kingdom: info.uk@fermator.com

www.fermator.com